

Simple Minute Timer

Construction and Operation Guide

Most commercial household timers have two or three buttons which must be held down or repeatedly pressed to enter the time, which can be a tedious process, and an LCD display, which can be difficult to see in poor lighting.

This compact, hand held, battery-powered timer solves those problems by using a keypad to allow the time to simply be typed in directly, and a bright LED display that's easily visible in bright or dim light. It also has a penetrating, yet not too loud, alarm

Features

- Bright four-digit LED display, showing hours and minutes
- Duration up to 99 hours and 99 minutes
- Alarm (piezo speaker)
- Flashing seconds indicator
- Simple keypad operation
- Timer can be paused
- Battery powered (2 × AA batteries)
- Turns itself off (goes to sleep) when not in use
- Low-battery indication
- Batteries easily changed – no need to open the case.

How it works

The circuit, built around a PIC16F690 microcontroller, is shown on the next page.

Two AA batteries provide a nominal 3V power supply. The PIC can operate down to 2.0V, so there is no need for regulation. However, as the battery voltage falls, the display will become dimmer. A “low battery” condition is indicated (by turning on the right-most decimal point) when the power supply falls to 2.4 V.

There is no power switch. Power is always supplied to the PIC, but it draws less than 10 μ A when in standby mode, where the display is blanked and only the PIC's Timer1 oscillator, driven by the 32.768 kHz crystal (loaded by the two 27 pF capacitors), is running. The batteries should be able to supply this standby current for years.

A 100 nF bypass capacitor helps stabilise the power supply to the PIC.

The display module consists of four common-cathode 7-segment LED displays with the anodes (one per segment) connected in parallel. These anodes are driven directly by the 16F690, via 47 Ω resistors, which limit the current in each segment to 19 mA, assuming a 2.0 V forward voltage drop across each segment LED and an output high voltage on the PIC of 2.9 V. This is well within the PIC's maximum current ratings for each pin and in total.

NPN transistors, driven via 1 k Ω resistors, are used to connect each display cathode (one per digit, and another for the ':') to ground.

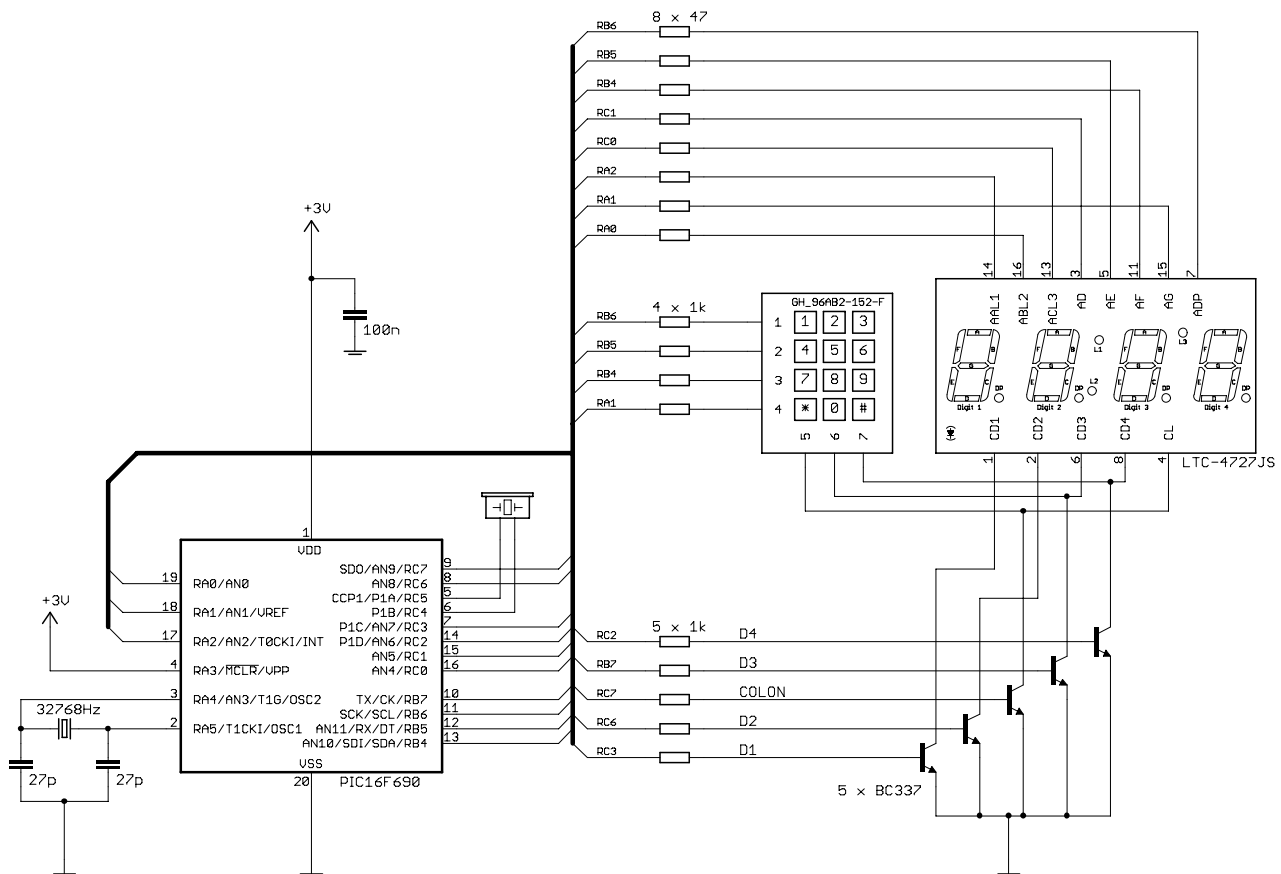

The displays are multiplexed; each transistor is turned on, one at a time, and the appropriate pattern output to the anode pins, to turn on the LED segments corresponding to a single digit to be displayed.

A timer-driven interrupt repeats this process almost 1000 times per second, meaning that, although only one digit is ever displayed at once, the overall display (all four digits plus ':') is refreshed almost 200 times per second; quickly enough that each digit appears to be continuously on.

The keypad consists of a four row \times three column matrix of pushbutton switches.

Three of the NPN transistors are used to pull the keypad columns low. Making the display-driving transistors do double-duty like this saves on transistors and PIC pins.

The keypad rows are connected to PIC pins, configured as digital inputs, with internal pull-ups enabled. This means that each pin will normally read high (or '1') until one of the keypad buttons, in whichever column is being pulled low, is pressed. By pulling each column low in turn, and reading the row inputs each time ('scanning' the keypad), it is possible to determine which keys are being pressed.

This scanning process is performed by the same interrupt routine which updates the display. Every 1.024 ms, it turns on one transistor, which pulls one display cathode and, for three of the transistors, one keypad column low. It then reads the keypad inputs (if applicable; not all of the transistors are connected to the keypad) and outputs the appropriate pattern for each digit to the display anodes. It also sounds the alarm, if it is enabled.

The alarm is a piezo speaker, driven by two PIC pins configured as complementary (one is the inverse of the other) PWM outputs, running at 4 kHz. Using complementary outputs in this way doubles the voltage seen by the piezo, significantly increasing the volume.

The PIC's Timer1 oscillator is used to drive the 32.768 kHz crystal, triggering an interrupt every two seconds, which in turn keeps track of the time.

As mentioned above, the Timer1 oscillator continues to run when the device is in standby (or sleep) mode. The PIC is configured to wake from sleep every two seconds, when TMR1 overflows. If the '*' key is pressed, the PIC stays awake and the minute timer comes back to life; otherwise it goes back to sleep for another two seconds.

Construction

The kit contains two single-sided printed circuit boards, connected by ribbon cables – a main board holding the microcontroller, and a display board on which the display and keypad are mounted. If they are delivered as a single board, you will need to snap along the scoring to separate them.

The main board is shown below, with a component overlay diagram on the right.

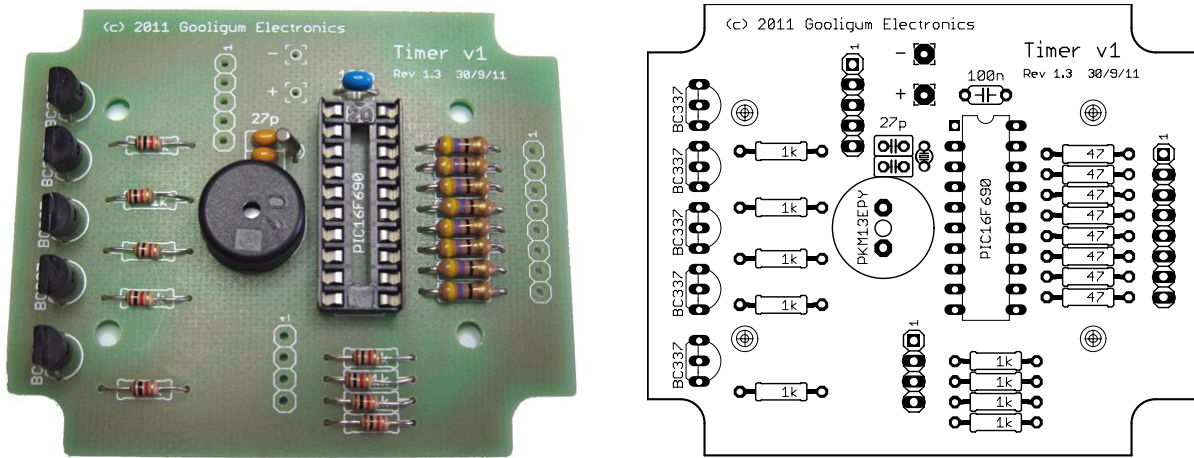

It is often easiest to build up a PCB by starting with the lowest-profile components, so begin by soldering the resistors to the main board, followed by the capacitors and IC socket, and then the crystal and transistors – orienting them as shown in the overlay. Finally, install the buzzer. Note that the buzzer sits approximately 1 mm off the board.

The display board, with the display module fitted, and its component overlay, are shown below.

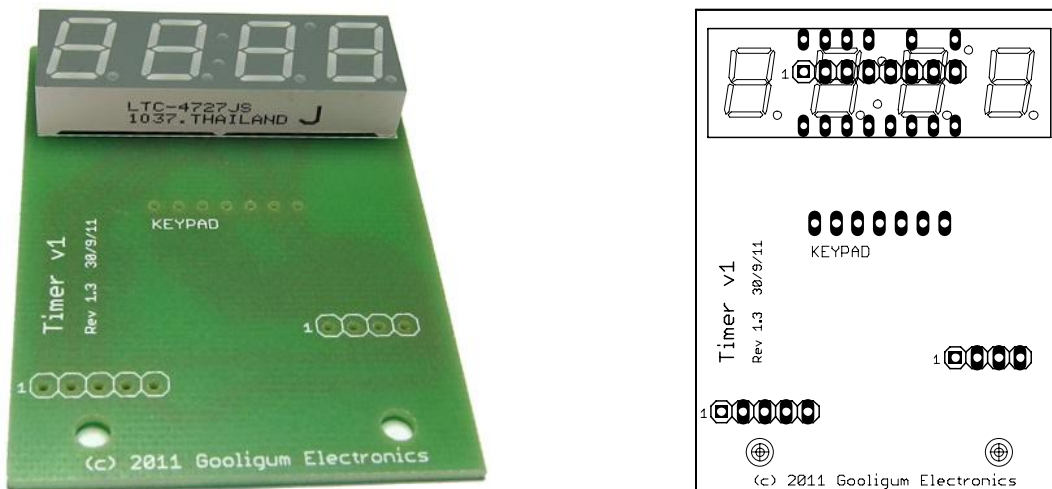

You can solder the 4-digit display module to the display board at this time, but before going further you need to prepare the enclosure.

The kit is designed to fit into a Hammond 1593Q hand-held instrument case, or equivalent. These cases include an inlay in the top section, a removable end panel (useful when they are used to build a remote control) and a battery compartment with a sliding door.

Print the drilling guide (downloadable from www.gooligum.com.au) and use a water-soluble glue to paste it to the inlay, with the LED display toward the removable panel end, as shown.



Use the guide to drill 4 x 2.5mm holes for the keypad mounting posts and to cut holes for the 4-digit LED display and keypad.

The cut-outs can be made fairly easily by drilling a series of small holes around the inside of the lines, cutting between the holes with a craft knife.

The slot for the keypad can be left rough, as it won't be visible.

Use a small file to slowly expand the display cut-out, regularly checking it against the display board until the display just fits, with the PCB lined up with the two mounting holes in the enclosure. Note that the other two mounting posts were within the display cut-out area and will have been removed.

Wash off the paper drilling guide with soapy water.

Temporarily press the keypad into place – it should be a tight fit – to check that the keypad pins correctly align with the holes in the display PCB and that the keypad pins reach far enough through the PCB to be soldered. They should just reach the copper layer. This is enough to make a good connection to each pad if you let the solder flow long enough. But to make certain, you may wish to lengthen the keypad pins by soldering solid wires (e.g. resistor lead cut-offs) to each.

Put a drop of glue (any suitable for plastics is ok, but “super glue” works well) on each keypad mounting hole, and press the keypad firmly into place.

You should also put a little of the same glue around the inside of the display cut-out, to glue the LED module to the case. A smear on each inside edge is plenty, if you've done a neat job of filing the cut-out to size.

Install the display PCB, with the display protruding a little past the outside of the case – just far enough to make it possible to solder the keypad pins. You can now screw the display PCB to the mounting holes, as shown.



The keypad pins can now be soldered to the display PCB.

Prepare the three lengths of flat ribbon cable (8-way, 5-way, and 4-way), each around 5 cm long. Making them longer can make assembly a little easier, but if they are too long it will be difficult to fit them into the enclosure – there’s not a lot of room in there!

Solder the ribbon cables to the pads on the display board, as shown.



It is easiest to install the (programmed) PIC16F690 in its socket now, before the ribbon cables are connected to the main board.

You can now solder the ribbon cables to the main board, connecting the two PCBs together. For each connection, pin 1 (square) on the display board connects to pin 1 on the main board. The cables remain straight, not twisted, as shown.

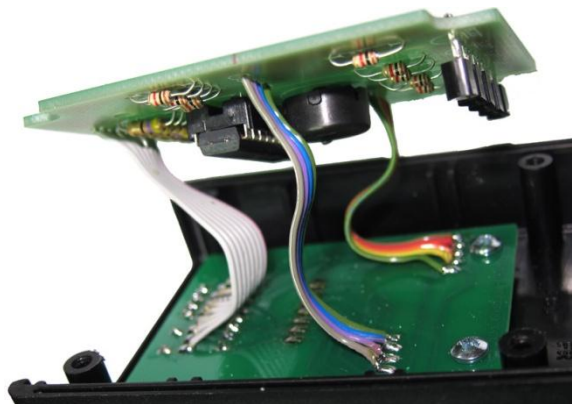

Next, affix the battery holder to the case.

You can use some strong plastics glue to affix the holder to the battery compartment in the bottom half of the case, as shown here – but it has to be a very strong, specialised plastics glue, which “welds” the surfaces together, because it has to withstand the force of batteries being inserted and removed.

Unlike the keypad and display module, “super glue” is NOT good enough here!



A more robust solution is to use double-sided adhesive tape to attach the battery holder to the top half of the case, above the battery compartment.

To do so, you must cut off the keypad mounting posts (side cutters do a good job), and thread the battery holder leads past the enclosure mounting pillars, as shown.



Cut the battery holder leads to around 9 cm long and solder them to the pins marked '+' and '-' on the main PCB.

It is now possible to test the timer – see the operating instructions, below.

If the timer works correctly, you can go ahead and screw the main board to the bottom of the enclosure, using the four PCB mounting posts. You will need to swivel the top part of the enclosure out of the way as shown below – hopefully you've made the cables long enough!



Tuck up the cables and then screw the enclosure halves together.

Remember to install the end panel first!

You can now test the timer again.

If the alarm is not loud enough, you can make it louder by drilling some holes in the end panel – after removing it from the case of course!

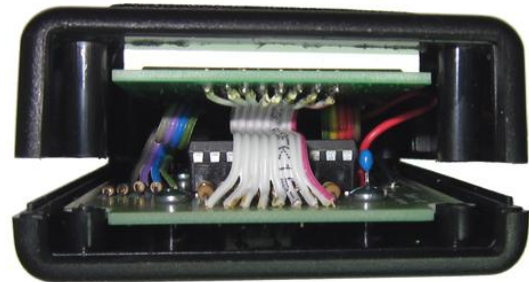

The full kit includes the top panel artwork, printed on an adhesive label. Alternatively, you can print the artwork from the PDF file available for download from www.gooligum.com.au.

Cut out the front label, removing the cut-outs for the display and keyboard with a sharp hobby knife. To make it easier to fit, you should cut around the outside of the lines.

You can now affix the label to the inlay section of the top panel, as shown.

Your timer is now ready to use!



Operation

Turn the minute timer on by pressing and holding the '*' key.

Use the numeric keypad to enter the time. The two digits to the right of the ':' represent hours and the two on the left are minutes. The maximum time you can enter is 99 hours and 99 minutes.

For example, if you want the alarm to sound after ninety minutes, type '90'. Or equivalently, you could type '130', which will show as "1:30", or one hour and thirty minutes.

To start the countdown, press '#'. The ':' on the display will flash, to show that the timer is running.

To pause the timer, press '#' again. The ':' will stop flashing and the time will stop counting down.

To resume the countdown, simply press '#' again.

When the alarm sounds, press '*' or '#' to silence it. Or wait twenty seconds and it will stop by itself.

Pressing '*' at any time will stop the timer and clear the display to "0:00". This is useful if you want to abort the countdown, or if you make a mistake when entering the time.

If the right-most decimal point lights, the batteries are getting low and it's time to change them!

To turn the timer off (place it in standby mode), press and hold the '*' key.

It will turn itself off, if no key is pressed for five minutes while the timer is stopped on "0:00".

Parts List

1	Pre-programmed PIC16F690-I/P
1	32768 Hz "watch" crystal (12.5 pF load capacitance)
2	27 pF ceramic capacitors
1	100 nF monolithic ceramic capacitor
8	47 Ω 1/4W resistors
9	1 k Ω 1/4W resistors
5	BC337 NPN transistors
1	10 mm 4-digit common cathode 7-segment LED display module (Lite-On LTC-4727JS)
1	3 \times 4 front-mount keypad (Grayhill 96AB2-152-F)
1	13 mm PCB ext drive piezo sounder, 5 mm spacing (e.g. muRata PKM13EPYH4000)
1	20-pin DIP IC socket
150 mm	8-way ribbon cable (or any suitable to make up 50 mm lengths of 8-way, 5-way and 4-way)
1	2-way AA flat battery holder with fly leads
1	Hand-held instrument case with battery compartment, at least 112 mm \times 66 mm \times 28 mm (e.g. Hammond 1593Q)
6	#4 or M2.5, 6 mm panhead machine screws
	Double-sided foam tape (optional, to mount battery holder – see text)